

LNG Road Tanker Loading

A brief guide to the initial steps for
planning and setting up a station
(or stations).

The Essential Guide

Contents

What is LNG?	4
How much tanker space do I need?	5
Rear Loading	6
Side Loading	10
Loading Islands	14
LNG Specifics	16
Layout Summary	17
The Loading Station	18
LNG Meter Skid	24
Insulation	28

What is LNG?

Natural Gas that has been cooled to a liquid form for transport and storage.

Key Facts

- Temperature: -162°C (-260°F)
- Volume Reduction: $1/600^{\text{th}}$ of its original volume
- Main component: Methane (CH_4)
- Other Hydrocarbons: Ethane, Propane, Butane (small amounts)
- The vapour created as the liquid warms is generally known as Boil-Off-Gas (B.O.G.)

How much tanker space do I need?

This is quite a simple exercise. A tanker is generally accepted as being 2.4m wide and, if it is an articulated single barrel vessel, it will be 16m long, including the tractor cab.

There may be slight length variances due to the type of tank.

Furthermore, a lot will depend on where the tanker connections are.
Rear or Side?

Rear Loading

If the tanker connections are at the rear, then there will be two ports (liquid and vapour) for the arms to connect to. The size of those ports will vary from country to country, so take nothing for granted.

The loading arms (liquid and vapour) will be designed so that whichever position the ports are in (liquid left, vapour right, or vice versa), the arms will cross over to make connection possible. Do not underestimate the potential for these variances.

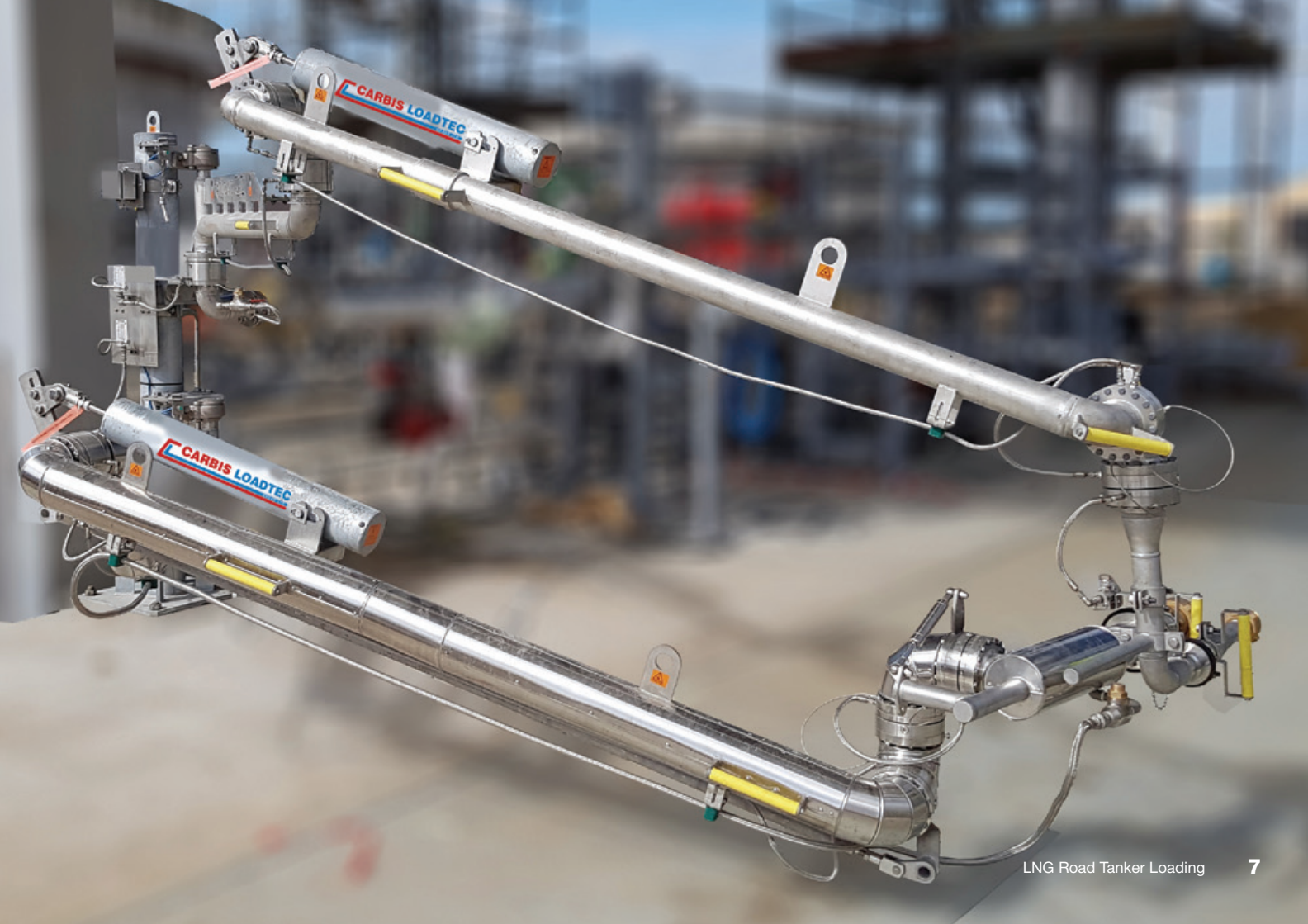

Rear Loading Bay Width

In this scenario, you can see that the distance from the centreline of tanker to the centreline of loading arm standpost will be 2430mm.

The tanker should be approx. 400/500mm from the kerb.

The loading bay can be 3500mm wide (kerb to kerb).

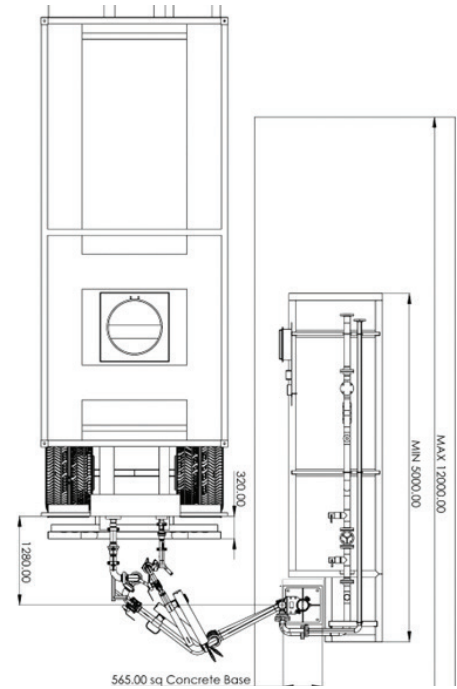
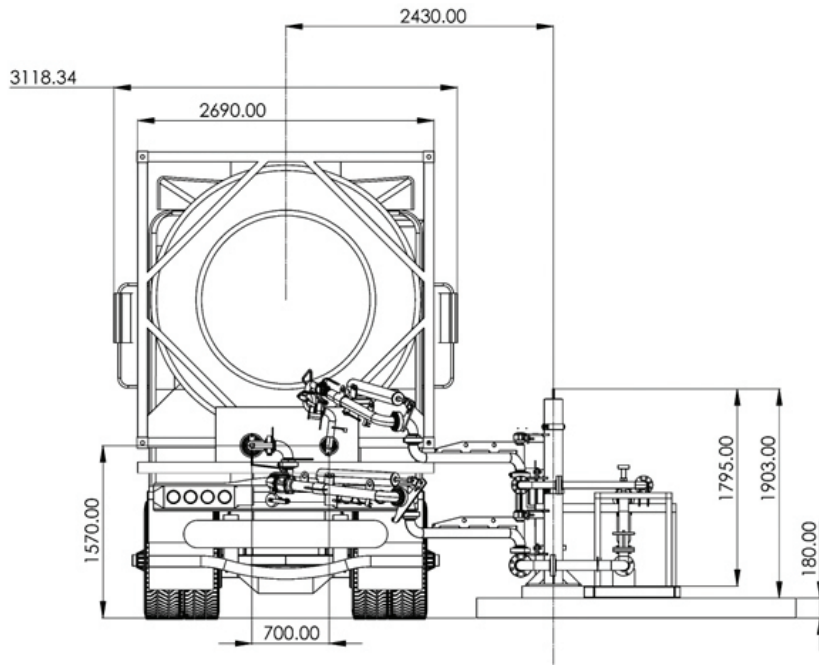

Side Loading

If the tanker connections are at the side, then there will be two ports (liquid and vapour) for the arms to connect to. They are likely to be lower to the ground than the rear connections. The size and linear position of those ports will vary from country to country, so take nothing for granted.

The loading arms (liquid and vapour) will be designed so that whichever position the ports are in (liquid left, vapour right, or opposite) the arms will cross over to make connection possible. Do not under-estimate the potential for these variances.

NOTE! Greater space is required.



Side Loading Bay Width

In this scenario you can see that the distance from the centreline of tanker to the centreline of loading arm standpost will be 3930mm.

The tanker should be approx. 1500mm from the kerb for operator access and safety.

The loading bay needs to be 5630mm wide (kerb to kerb).

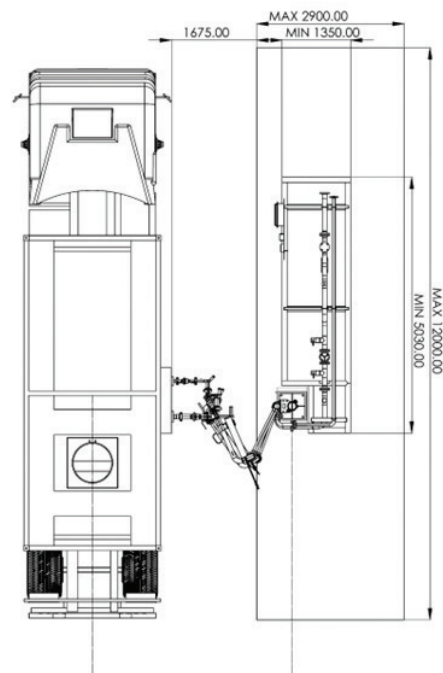
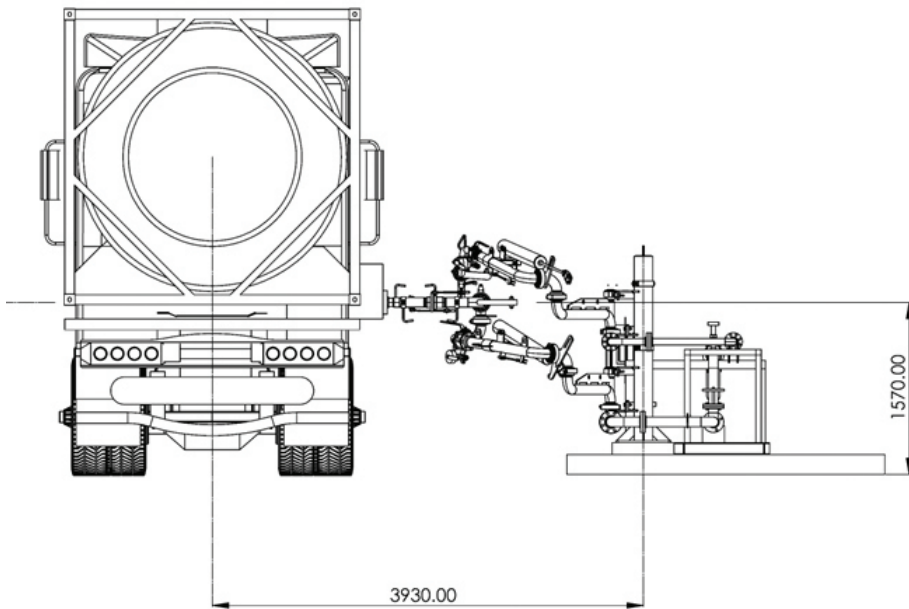



CARBIS LOADTEC

LNG Specifics

The loading arm will be made from 316L stainless steel.

All the swivel joints must have a Nitrogen purge facility to ensure the ball tracks do not have moisture within them that may freeze and prevent movement.

The end connection is determined by what is fitted to the tanker and normally this is an industry approved Dry-Disconnect coupling.

The Liquid arm shall be insulated for safety and cold retention.



Layout Summary

The most compact arrangement is to have rear connections, as this enables the potential for double-sided islands (as shown on the previous page).

However, if side-loaded tankers are used, the connections will most likely be on only one side.

The other point to note is whether the B.O.G (Boil-off Gas/Vapour Return) will be recompressed and returned to storage or utilised for energy generation on site. If used, then it is likely the metering skid will require an extra meter in that B.O.G. line to measure and record the mass of B.O.G. used.

The Loading Station



Loading Station Design Features

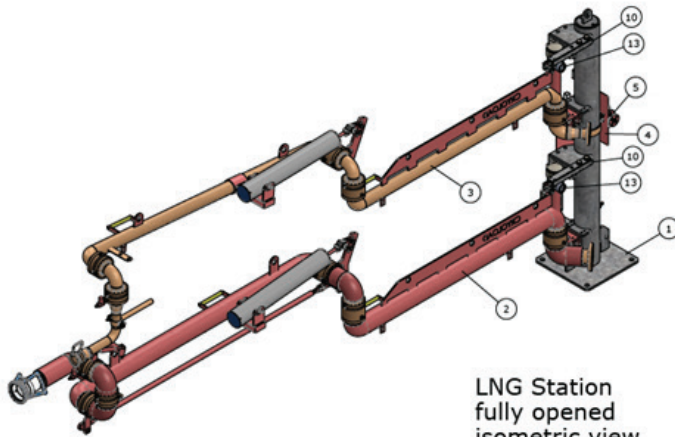

LNG Station
fully opened
isometric view

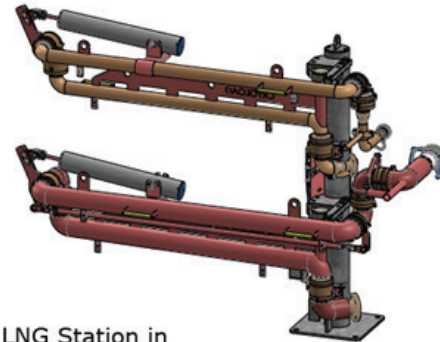

LNG Station in
parking position
isometric view

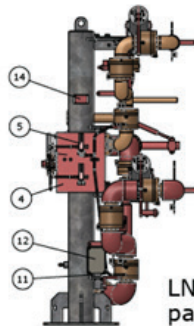

LNG Station in
parking position
left side

Loading Station Design Features

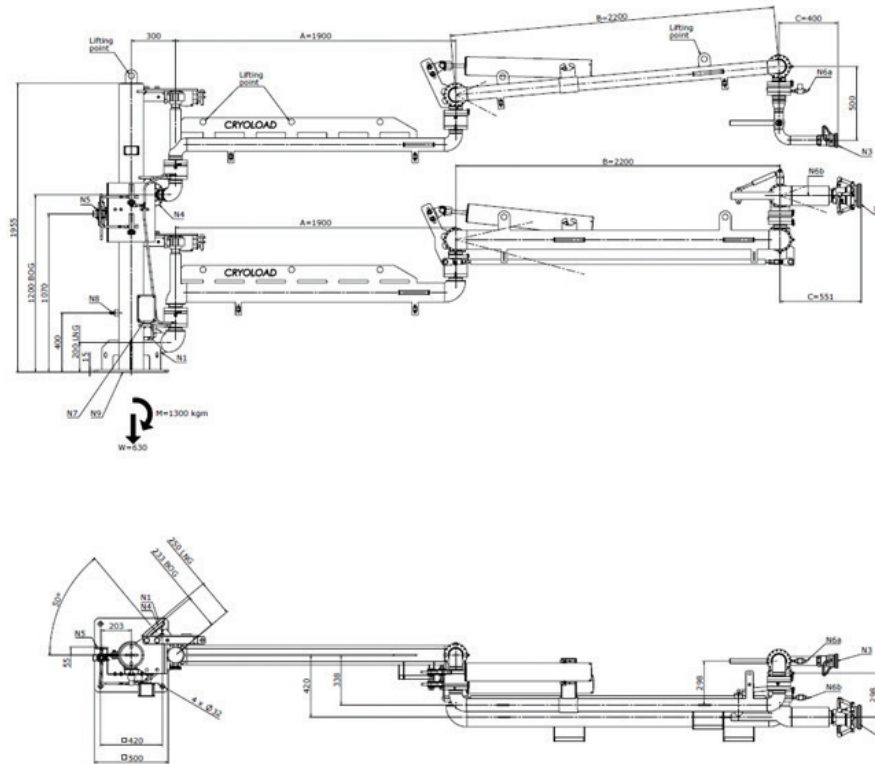

Loading Station Explained

Let's do a walk through pages 20 and 21. This is a typical LNG Loading Station.

1. Both arms are mounted on a common standpost. This is galvanised steel and will have an earthing boss.
2. The client will decide whether they want parking switches for the arms or simple latches. The switches can be linked to a traffic barrier or Stop/Go lights.
3. The lower arm is a 3" liquid line with six swivel joints for easier articulation.
4. The upper is the vapour return with five swivels. It is also 3" for strength, reduced down to 2" for the tanker connection.
5. These arms can be 2", 3" or 4".
6. Both arms carry the same hardware.
 - Spring balance cylinder
 - Special LNG swivel joints with N2 purge
 - Tanker connection - in this case, LNG Dry disconnect couplers
 - Optionally, Breakaway couplers can be fitted to protect the arm and contents in the event of an unplanned diveaway while the arms are connected.

Due to the use of the dry disconnect, an in-line valve is not required. In this case, when the arms have completed loading/vapour return, they will park onto match dry-disconnect adapters and be purged empty, allowing the arm to return to an ambient state.

The arms are fitted with special cold-resistant handles for comfortable articulation.

Design Features - N2 Purge

The Nitrogen purge system must be used in this application. Its distribution system allows each swivel to have a flow and return.

Optionally, the system can be enhanced to incorporate swivel monitoring. The system will continuously monitor the N2 flow in each swivel. If any inconsistencies are detected, it will notify the client (or Carbis Loadtec, if preferred) that a swivel may need attention.



Design Features - Factory Test

Our normal Factory Acceptance Test (FAT) involves an ambient pressure test.

Optionally, clients can choose a liquid nitrogen test to simulate the working conditions and prove operability under simulated working conditions.



LNG Meter Skid

The Meter Skid Explained

The meter skid is an open book. It can vary in length, width, complexity and functionality.

Essentially, it measures the mass and controls the functionality of the loading system to prevent overfilling. This is where it can get a little complex.

Every meter skid should comprise the following features for good practice.

- Manual valve isolation at each end of the skid for each line.
- A Mass Meter per line
- A Control Valve per line
- An Emergency Valve per line
- Meter Proving connections
- Temperature and Pressure instruments
- Pressure relief valves
- Batch controller
- Electrical distribution panel
- Tanker Earthing system
- Drain down facilities

Furthermore, The B.O.G. line may also be fitted with a meter to measure the vapours returned for fiscal purposes.

Beyond this, it depends on the client's preferences, and we can adjust to any situation.

Flow Control Skid

There are a number of instances where the tanker is loaded while on a weighscale. In that case, there is no requirement for the meter package. The weighscale software needs to communicate with the control skid to ensure valves are open and closed as appropriate. In these cases, we can supply a pre-packaged solution for valve control.

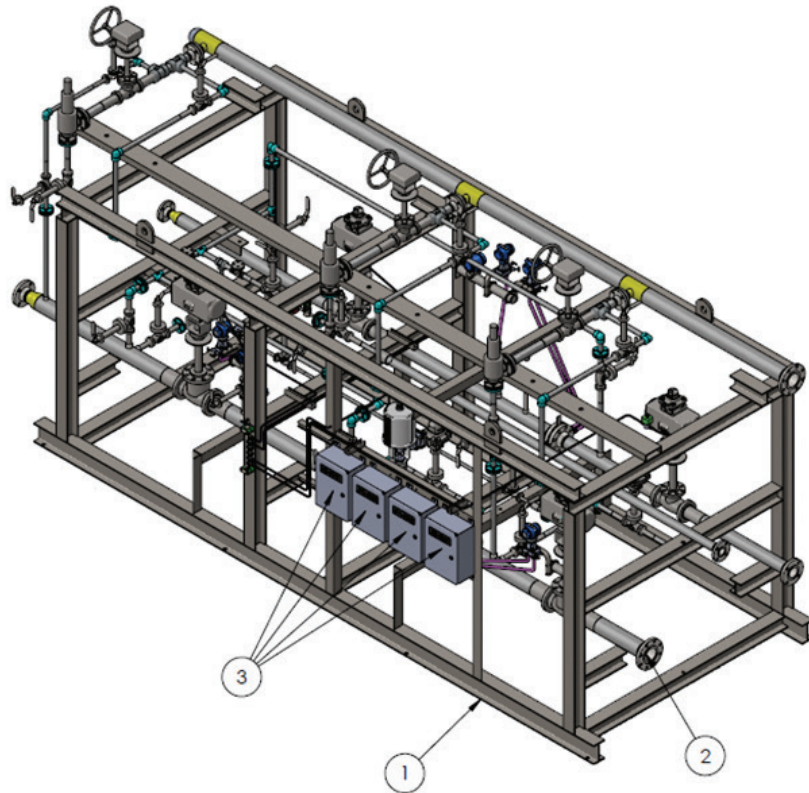

Insulation

LNG Liquid arms must be insulated which is common industry practice for cryogenic lines where cold conservation is needed.

It is recommended to have the loading arms insulated at the factory. The need to cater for swivel joint arcs of movement and maintenance requirements makes it a specialist operation.

However, it is not recommended to insulate the skids until after arrival at site. The presence of multiple flange joints and the handling of a heavy, large structure require a site pressure test for safety. Once the test is successfully completed, insulation can proceed.



Meter Skid Length

Irrespective of tanker, the length and width of the meter skid will vary depending on content.

The drawing indicates that a length between 5,000mm and 12,000mm can be considered.

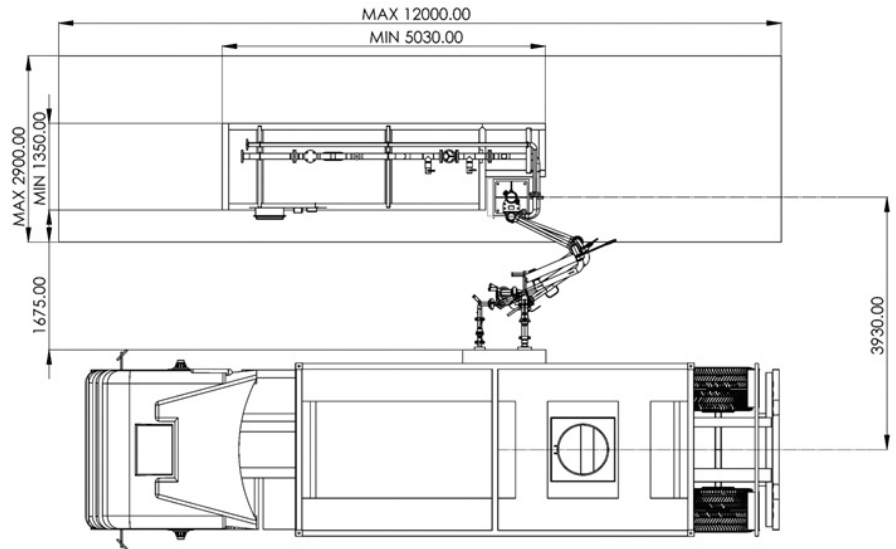

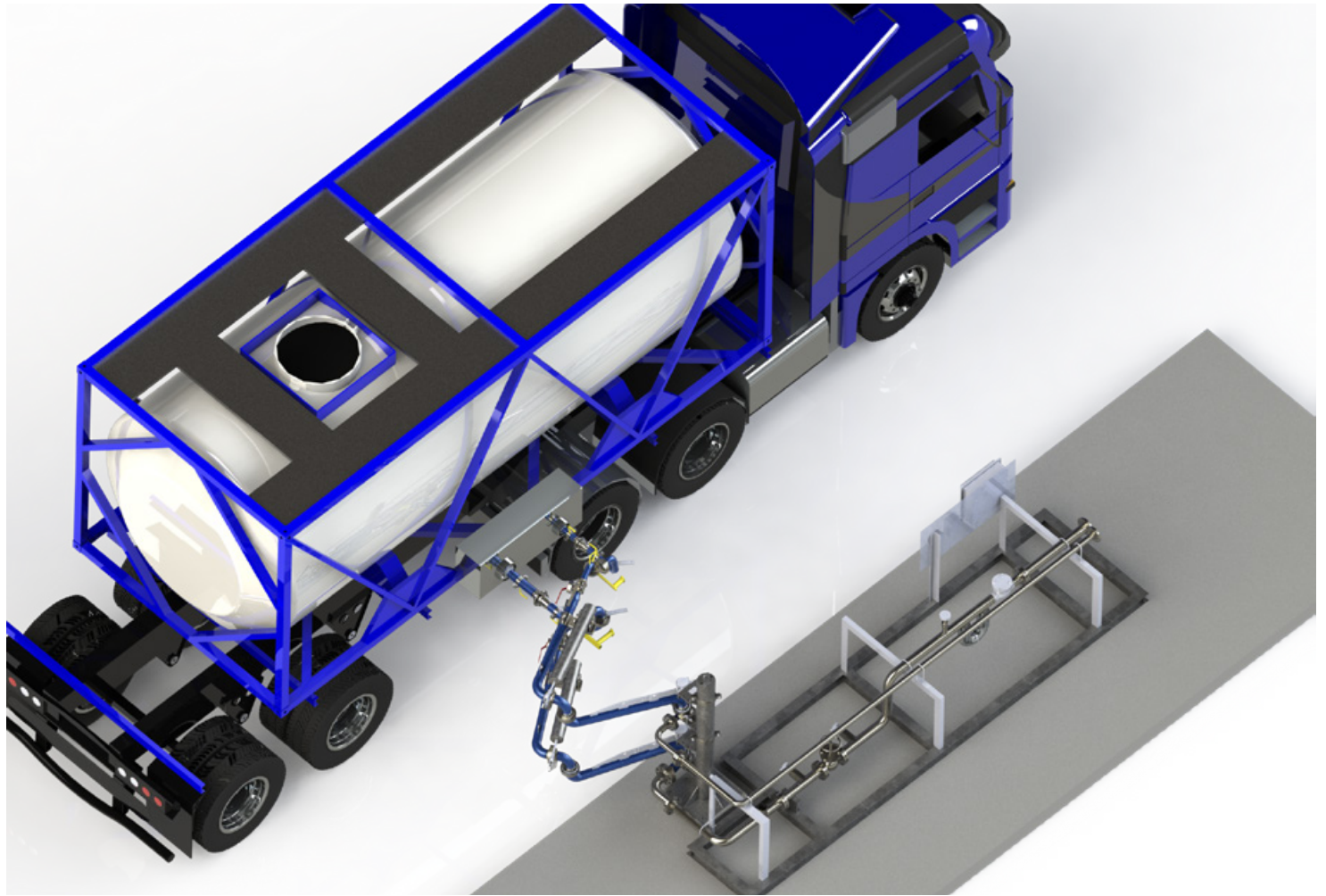

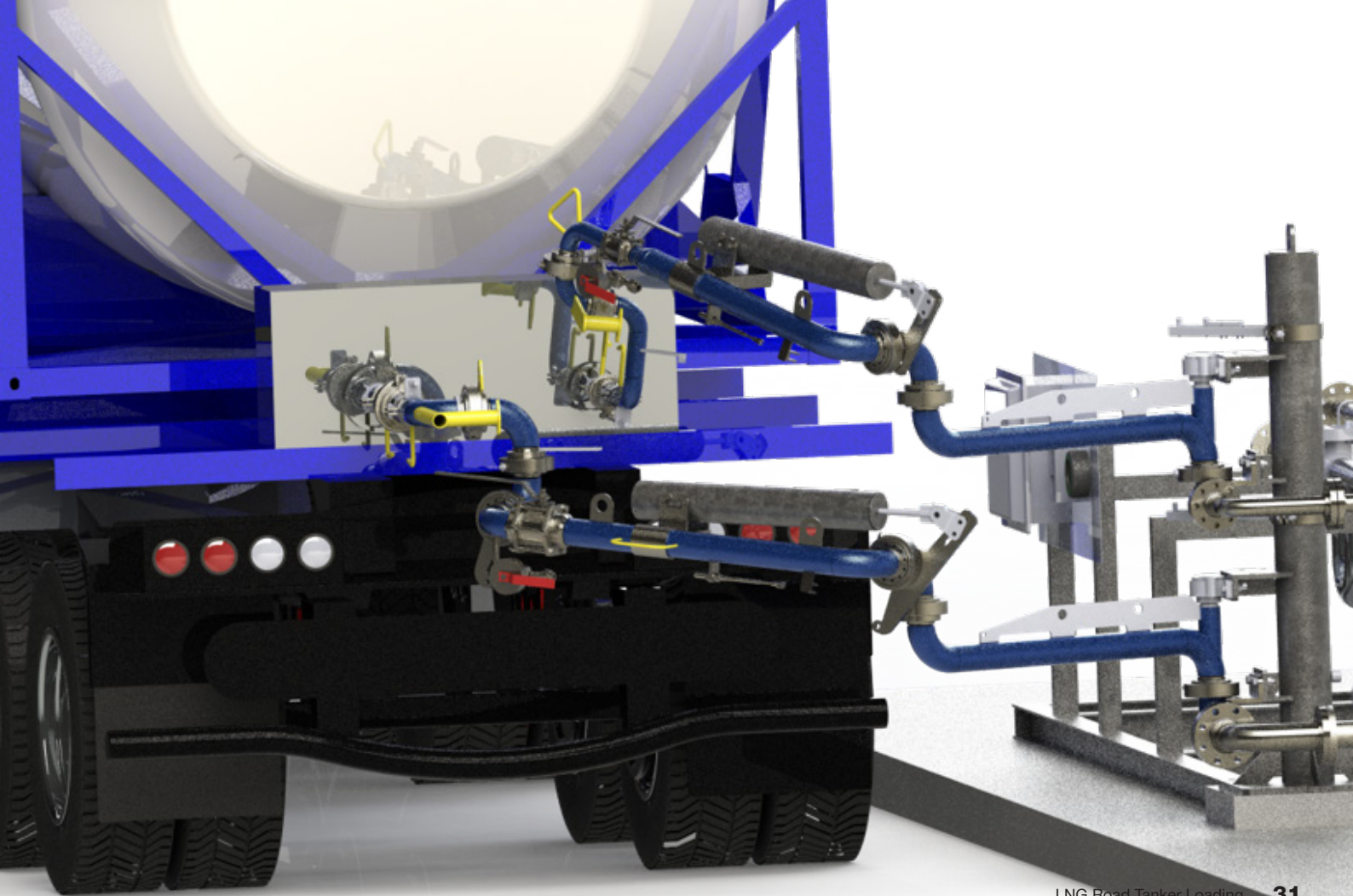



The Stables, Coach House, Hythe Road, Smeeth, Kent, TN25 6SP, UK

Tel: +44 (0) 1303 81 30 30 **Email:** info@carbisloadtec.com

Website: www.carbisloadtec.com